

Application

- Multiple Equipment

Dual Port Filtration Systems

Spec No. _____

Quantity _____



CFS3-EL

Product Features

- ◆ Separate prefilter can be plumbed in front of booster pumps for additional protection. Prefilter also extends life of downstream cartridges, lowering operating costs.
- ◆ Unibody manifold with parallel flow provides high flow rates and gallon capacities for higher output applications.
- ◆ SQC™ - Sanitary Quick Change encapsulated design reduces contamination during change-outs and are disposable and incinerable.
- ◆ Pressure gauge with red follower needle allows the filter pressure to be monitored and indicates when the cartridges are reaching the end of their service life.
- ◆ FDA CFR-21 and/or NSF compliant materials provide peace of mind that this product is suitable for potable applications.

The CFS3-EL water filtration system is engineered to provide high flow rates and capacities in a single compact package. The graded density media design reduces sediment particles that can cause beverages and ice to be cloudy and unappealing while protecting downstream equipment. Premium activated carbon reduces chlorine taste and odor for consistent great tasting cold beverages, hot beverages and ice. A dedicated scale inhibition cartridge reduces scale build-up on evaporator plates and heating coils in both ice machines and coffee brewers. The CFS3-EL reduces filterable cysts to maintain drinking water quality.

Product Specifications

Model Number	Part Number	Reduction Claims	Micron Rating	Capacity	System Flow Rate*	Application	Replacement Cartridge	Qty	Sizing
CFS3-EL	55736-08	Sediment, Chlorine, Cyst, Scale	0.5	42,000 gallons (158,987 liters)	5 gpm (18.9 lpm)	Cyst	CFS8504-B	1	For dual brewers, single and dual carbonators, and ice machines up to 800 lbs (363 kg)
							CFS8812ELX	3	
							CFS8000-S*	1	

* Note: System flow rate is reduced to 2 gpm to equipment being fed with a scale inhibition cartridge.



Visit www.nsf.org for the claims associated with products that are NSF listed.



Water Filter Systems

Foodservice

CFS3-EL Dual Port Filtration Systems

Spec No. _____
 Quantity _____
 Model Number _____
 Part Number _____

Physical Specifications:

- System to incorporate a high flow, unibody manifold design.
- System to incorporate a 20" prefilter housing with a positive piston seal and built-in shut-off valve.
- System to be a parallel flow design with two outlet connections.
- System to incorporate a dedicated scale inhibition cartridge.
- Each chlorine taste & odor filter to incorporate a piston lock.
- System to be manufactured from FDA CFR-21 and/or NSF compliant materials.
- System to carry an NSF Performance Data Sheet (PDS)*.
- Filter cartridges to be non-activation type.
- Post-filter cartridges to be double o-ring type seal.
- Chlorine taste and odor cartridges to incorporate activated carbon.
- Scale inhibition cartridge to contain a time-released food grade scale inhibition material.
- Cartridges to be sanitary in design, requiring no contact with the media during filter change-out.
- Each system to have a 0.5 micron nominal particle reduction capability.
- Each system will reduce chlorine taste and odor for 42,000 gallons (158,987 liters).
- Each system will have a service flow rate for 5 gpm (18.9 lpm).
- System to have maximum operating pressure of 125 psi (862 kPa) and operating temperature of 100°F (38°C).

* For NSF listed product.

Installation Tips:

- Shut off downstream equipment prior to installation of the system.
- Do not exceed operating parameters for temperature or pressure.
- Do not install outdoors.
- For cold water use only.
- For commercial use only.

Do not use with water that is microbiologically unsafe or of unknown quality without adequate disinfection before or after the system. Systems certified for cyst reduction may be used on disinfected water that may contain filterable cysts. EPA Establishment Number 070595-CT-001.

CUNO Incorporated recommends regularly scheduled maintenance and replacement of the filter cartridge(s) in order for the product to perform as advertised/sold.

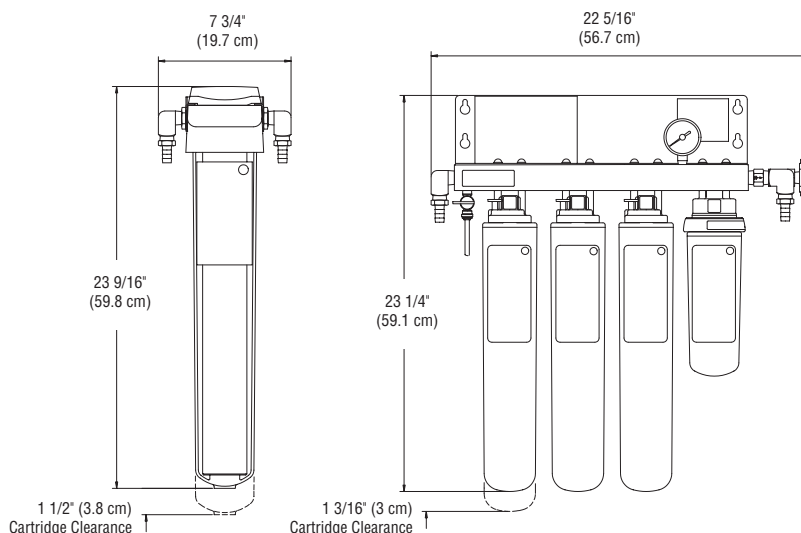

Limited 5 Year Warranty

CUNO Incorporated warrants to the original purchaser-consumer that this product is free from defects in materials and workmanship. This warranty, together with any and all warranties implied by law, shall be limited to a period of five (5) years from the date of original purchase by the consumer. This warranty does not apply to failures that result from abuse, misuse, alteration or damage not caused by CUNO. This warranty is subject to exclusions and limitations. Please refer to the Warranty Card provided with the product for details.

Service Worldwide

China
 CUNO Filtration Shanghai Co. Ltd.
 No. 2 Plant East Side
 Xin Miao San Road
 XinQiao Town SongJiang District
 Shanghai, China 201612

Australia
 CUNO Pacific Pty Ltd.
 140 Sunnholt Road
 Blacktown, N.S.W. 2148
 Australia

Europe
 CUNO Limited
 21 Woking Business Park
 Albert Drive
 Woking, Surrey
 GU21 5JY, England



Japan
 CUNO K.K.
 Hodogaya Station Building 6F
 1-7, Iwai-Cho, Hodogaya-Ku
 Yokohama 240-0023, Japan

Brazil
 CUNO Latina Ltda
 Rua AMF do Brazil - 251
 18120 Mairinque-SP, Brazil

Singapore
 CUNO Filtration Asia Pte Ltd
 18 Tuas Link 1
 3rd Floor
 Singapore 638599

CUNO Incorporated
 400 Research Parkway
 Meriden, CT 06450, USA
 Toll Free: 1-888-218-CUNO
 Worldwide: 203-237-5541
 Fax: 203-238-8701